

REVISIONS			
REV.	DESCRIPTION	DATE	APPROVED
A	Konstruktion genomgången, typ A/C införda	2021-07-15	MM

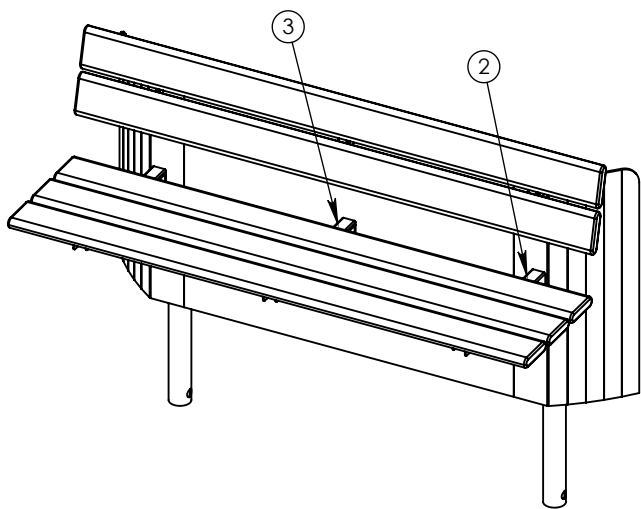

ITEM NO.	QTY.	PART NUMBER	DESCRIPTION	Weight
1	1	E5816101	Pile Bench	65.00
2	1	E5816102H	Sitskonsol höger	0.88
3	2	E5816102V	Fästvinkel sits	0.88
4	3	E5816103	Ryggkonsol	0.30
5	2	E5816104	Pile bench nedgjutningsben	2.04
6	6	K101703	BRB M8 8,4x16x1,6 A2	0.00
7	6	K203701	BRB 10,5x20x2 A2	0.00
8	9	K203724	MC6S M8x16 A4	0.01
9	30	K2530	RTS A2 6,3x25	0.01
10	6	K6110	M6S M10x16 A2	
11	5	T5816101	Trä Pile bench	1.79

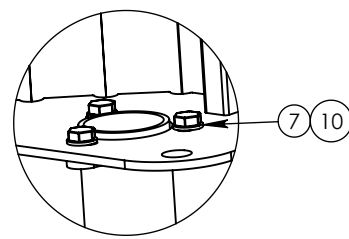
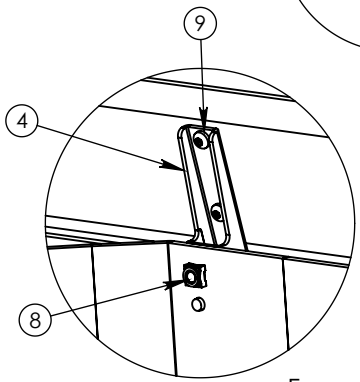
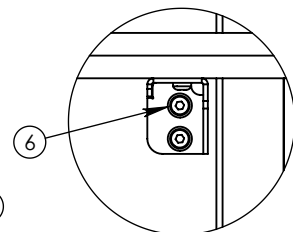
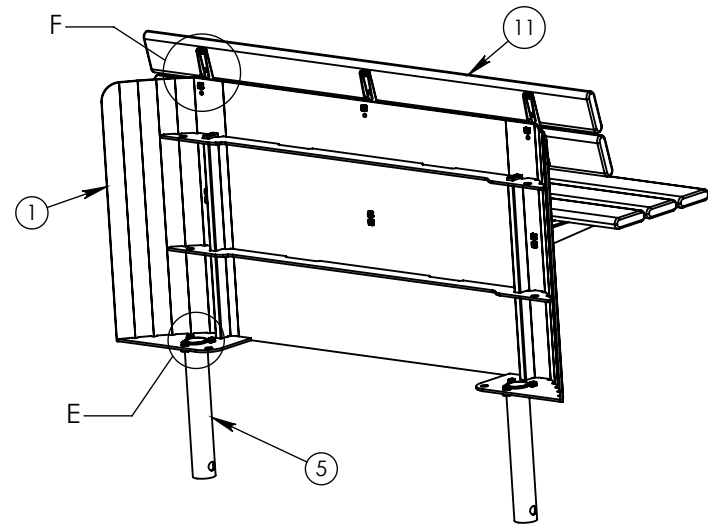
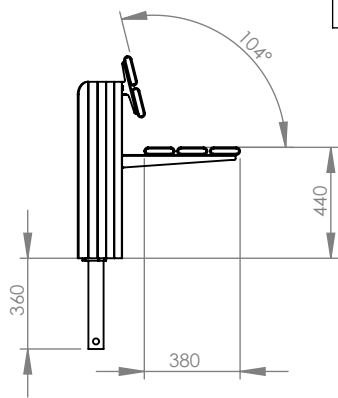
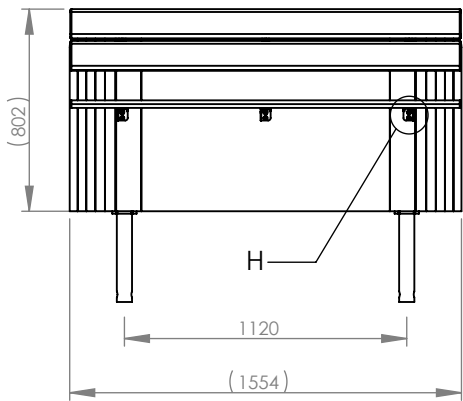

PO Box 49 Tåsen  
0801 Oslo  
Norway  
tel: +47 23 00 78 41  
tel: +47 23 00 78 40  
post@vestre.com  
www.vestre.com

Product series <b>Habitats</b>	Part Number <b>5816-901C</b>	Surface area <b>5915391.92 mm<sup>2</sup></b>
Designed by <b>Renè Hougard</b>	Description <b>Pile Bench Typ C</b>	Total weight <b>82.09 kg</b>
Engineer <b>Erik Emanuelsson</b>	Date <b>2021-03-15</b>	Scale <b>1:20</b>
Approved by <b>MM</b>	Sheet size <b>A4</b>	Sheet number <b>1/2</b>

All designs, drawings and pictures are the intellectual property of Vestre and are protected by Norwegian and international copyright laws. You may not use, distribute, modify, reproduce or otherwise exploit Vestre's designs, drawings and pictures without prior express consent by Vestre.

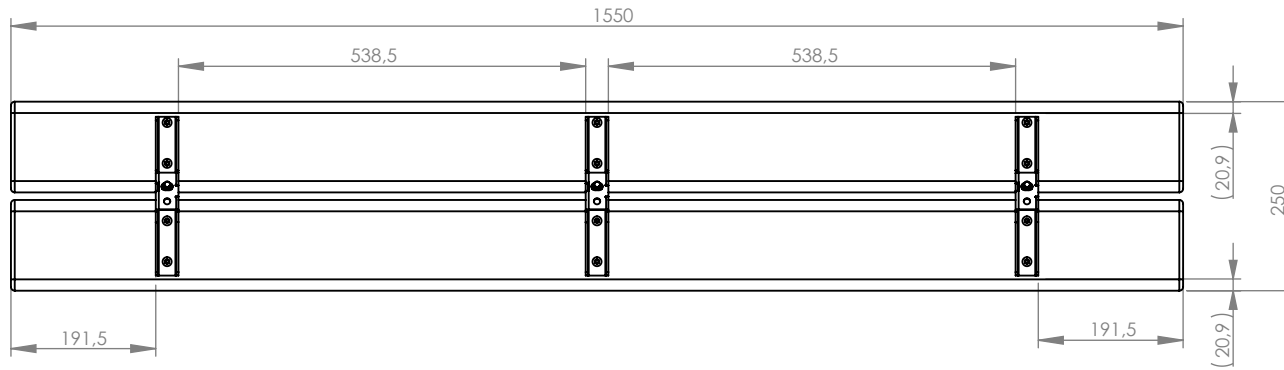

# Rygg

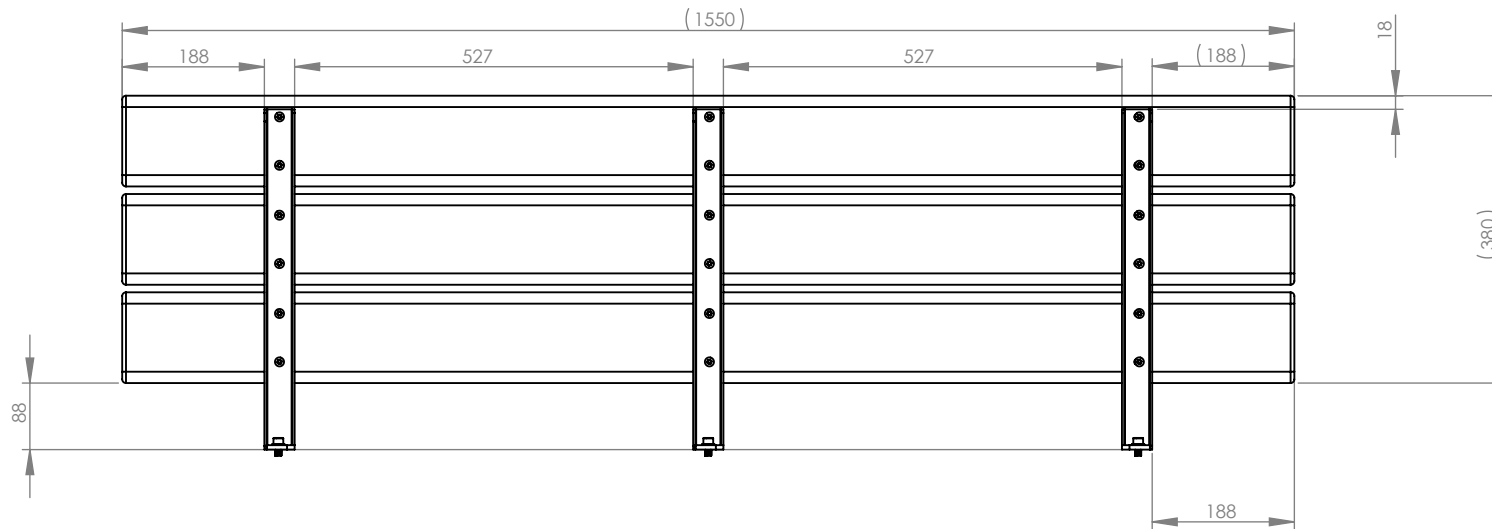

# Sits



All designs, drawings and pictures are the intellectual property of Vestre and are protected by Norwegian and international copyright laws. You may not use, distribute, modify, reproduce or otherwise exploit Vestres designs, drawings and pictures without prior express consent by Vestre.

	PO Box 49 Tåsen 0801 Oslo Norway tel: +47 23 00 78 41 tel: +47 23 00 78 40 post@vestre.com www.vestre.com	Product series <b>Habitats</b>	Part Number <b>5816-901C</b>	Surface area <b>5915391.92 mm<sup>2</sup></b>
	Designed by <b>Renè Hougaard</b>	Description <b>Pile Bench Typ C</b>		
	Engineer <b>Erik Emanuelsson</b>	Total weight <b>82.09 kg</b>	Scale <b>1:20</b>	
	Approved by <b>MM</b>	Date <b>2021-03-15</b>	Sheet size <b>A4</b>	